

# FCW-44 Firestop Cable Way

## PRODUCT DESCRIPTION

PFP Partners' FCW-44 are made with a durable one-piece powder coated steel case that contains intumescent core designed to firestop combustible pipes. In the case of a fire, the FCW's intumescent core strips expand to constrict to close off and seal around cables and voids.

FCW-44 have been tested and listed as a firestop device for use on voids, conduits, cables and wires.

FCW-44 two-piece design allows an easy retrofit solution to pre-existing cable or void installations.

The FCW-44 is non-hazardous, safe for the environment and does not require special shipping procedures. It does not contain solvents and is VOC compliant.

Meets the green building guidelines for adhesives and sealants as specified by both the US and Canada Green Building Council's LEED (Leadership in Energy and Environmental Design) Green Building Rating Systems.

## GENERAL APPLICATIONS AND USES

FCW-44s have been designed specifically to seal electrical cable/wires and future cable/wire penetrations against the spread of fire, smoke, fumes and toxic gases in 1 & 2 hour rated wall assemblies.

The FCW-44s have been tested and approved as a firestop device by Intertek Testing Services - Warnock Hersey (WHi) and meets the requirements of ASTM E814, CAN/ULC S115 and UL 1479.

Refer to WHi published Fire Resistance Directories or its websites. PFP Partners recommends that this product be installed by those trained in proper installation procedures (TQ Card) and be able to read and understand a firestop system design listing (i.e. UL and/or WHi listing designs).

### Tested and Classified for use in Fire Rated Assemblies:

- Concrete Walls
- Framed Walls

### Firestopping Penetration Items:

- Conduit
- Electrical Cables
- Electrical Wires
- Voids

## PRODUCT FEATURES

- Easily installed – new installation or as a retrofit existing installation
- Easily identifiable as a firestop device
- Environmental Safe – No harmful components, solvent free and is VOC compliant – LEEDs – California Air Resource Board SCM Districts – Rule 113 – South Coast Air Quality Management Districts (SCAQMD)
- Inert formula will not interact with substrates
- Product is stable over several freeze/thaw cycles; however, care should be taken to not freeze the product
- Product is mold and mildew resistant
- Post-consumer recyclable

## TECHNICAL DATA

Housing	Two piece powder coated steel case	Color	Red
Shelf Life	No applicable when stored in its original undamaged, unopened packaging (when stored in a cool dry place, 40°F to 90°F (4°C to 32°C)). All items should be warmed to at least 45°F (7°C) prior to installation.	Expansion Material	Intumescent core
In-Service Temperature	Up to 180°F (82°C)	Volume Expansion	1000% (free expansion)
		Intumescent Temperature	302°F (150°C)
		VOC (less water)	0

SECTION CONTENTS	Page No.
General Information.....	1
Technical Data .....	2
Installation Guidelines and Suggested Use.....	3
Ordering Information.....	4



FCW-44 – Firestop Cable Way

### PACKAGING

4 inch by 4 inch by 10-1/2 inches  
(101 mm by 101 mm by 267 mm)

### COLOR

Red

FCW - 44

Disclaimer: All technical advices, recommendations and services rendered by the seller are gratis. They are based on technical data which the seller believes to be reliable and are intended for use by person having the skills and know how at their own discretion and risk. In no event will the seller be liable for any consequential damages arising out of the use of this product.





FCW – 44

**MAINTENANCE**

The FCW-44s do not require maintenance after installation. If, after installation, the firestop sealant is damaged or cut, repairs should be made with the same sealant. Use only materials approved by through-penetration firestop manufacturer as suitable for repair of original seal. Never mix different manufacturer’s firestopping materials or devices.

**CHEMICAL COMPATIBILITY**

The FCW-44s are chemically compatible with all types of metal and plastic coated cable/wires listed in the system designs.

**STORAGE, HANDLING, TRANSPORTATION**

Manufacturer recommends storage temperatures between 40°F to 90°F (4°C to 32°C). Keep product stored in a protected covered area in its original containers. Storage in high heat, high humidity conditions may reduce products shelf life. A stock rotation program is recommended. Transportation temperatures 40°F to 90°F (4°C to 32°C) **DO NOT ALLOW TO FREEZE**

**WARRANTY**

Passive Fire Protection Partners will not accept liability for more than product refund. Any claim regarding product defect must be received in writing within 1 year from date of shipment. Passive Fire Protection Partners makes no other warranty or guarantee, express or implied, including warranties or fitness for a particular purpose or merchantability. The seller shall assume on other liability for incidental or consequential damages arising out of the sale or use of this product.

**INSTALLATION GUIDELINES AND SUGGESTED USE**

**Application**

- Method: Cut correct size of opening; slide FCW-44 into opening; attach clamps to both sides of the wall; install cables and smoke plugs.

**Installation Preparation**

- FCW-44s should be applied to surfaces that are dry, clean and free of dust, dirt and grease.

**Health and Safety**

- Hand and eye protection is highly recommended all sealants, consult the MSDS.

**First Aid**

- In case of contact with eyes, flush with large amount of water and consult a physician. For skin contact, wash thoroughly with soapy water. Contact a physician if skin irritation develops or persists. Consult the MSDS for additional information.

**Special Application**

- FCW-44s collars should not be installed in submerged conditions.

**LIMITATIONS**

This product is not designed to be a waterproof seal. Not recommended for continuous submersion or use below the waterline. For best results, store and install above 45°F (7°C). Application of this product is not recommended when frost or moisture is present on the surface.

**ORDERING INFORMATION**

**FWS-44 – Firestop Cable Way - Packaging**

Code	Packaging Size	Mounting Bracket	Color	Units per Carton	Units per Skid
FCW-44FWB	4 inch by 4 inch by 10-1/2 inch (101 mm by 101 mm by 267 mm)	Corner Brackets	Red	6	360
FCW-44FWC	4 inch by 4 inch by 10-1/2 inch (101 mm by 101 mm by 267 mm)	Wall Clamps	Red	6	360

Disclaimer: All technical advices, recommendations and services rendered by the seller are gratis. They are based on technical data which the seller believes to be reliable and are intended for use by person having the skills and know how at their own discretion and risk. In no event will the seller be liable for any consequential damages arising out of the use of this product.



Recycled Recyclable



1.800.810.1788 Technical Support  
1.800.810.1788 Customer Service  
©2010 PFP Partners. All rights reserved.

www.firestop.com  
email: firestop@firestop.com

**Passive Fire Protection Partners**  
1412 Derwent Way Delta, BC V3M 6H9

**Installation Instruction for Multiple FCW-44 Using the Wall Clamps**  
**New Construction**

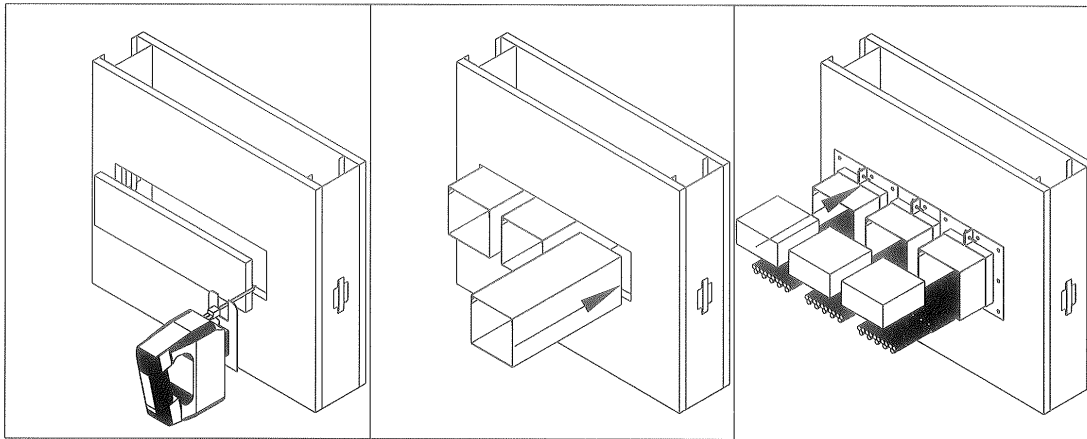

Cut correct size of opening

Slide FCW-44s into opening; leaving 28.6 mm (1-1/8 in.) between FCWs

Attach brackets together and then attach brackets to both sides of the wall; install cables & smoke plug

FCW - 44

**Retro**

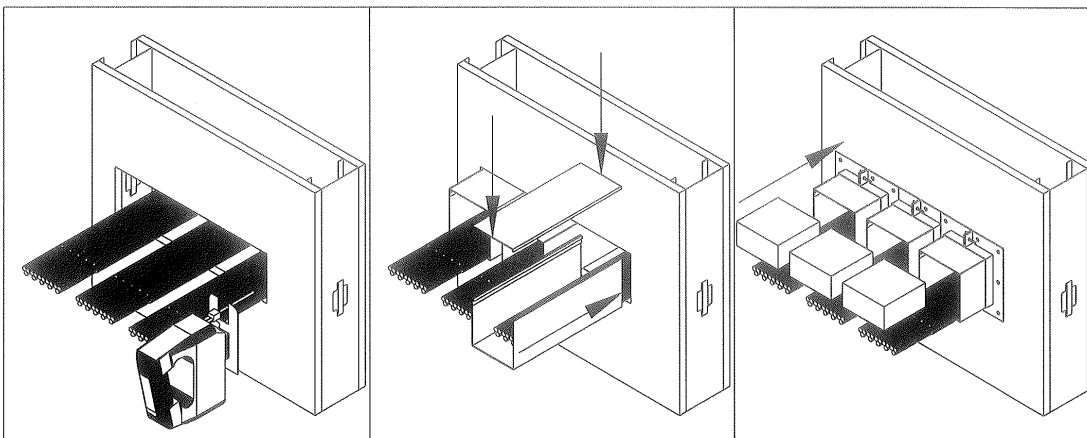

Cut opening to the correct size

Fit cables into the bottom of the FCW-44; close the lid and slide the FCW-44 into the opening leave 28.6 mm (1-1/8 in.) between FCWs

Attach brackets together and then attach brackets to both sides of the wall; install cables & smoke plug



Bolt brackets together using the center hole; then install and bolt the brackets together at the top and bottom of the bracket attaching the brackets to wall using drywall screws or concrete anchors depending on wall

Disclaimer: All technical advices, recommendations and services rendered by the seller are gratis. They are based on technical data which the seller believes to be reliable and are intended for use by person having the skills and know how at their own discretion and risk. In no event will the seller be liable for any consequential damages arising out of the use of this product.



FCW - 44

### Installation Instruction for Multiple FCW-44 Using the Corner Brackets New Construction

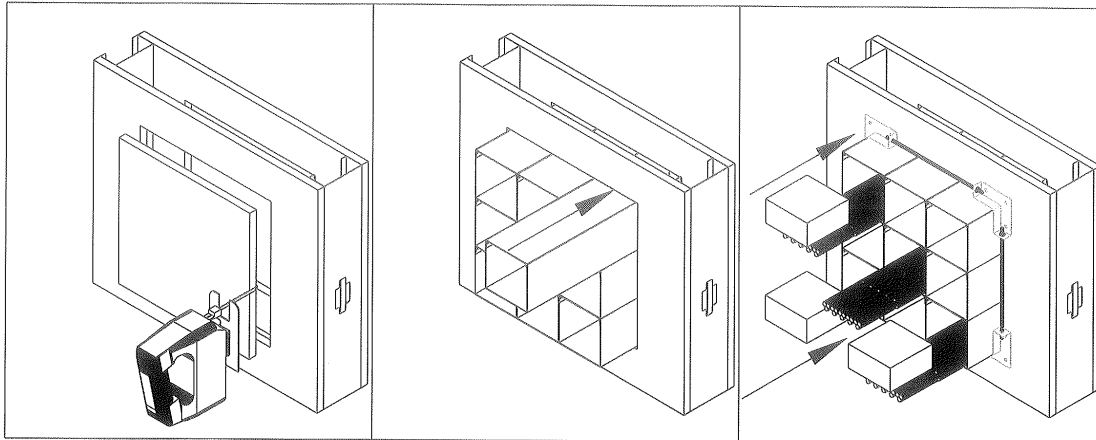

Cut opening to the correct size

Slide FCW-44s into opening, FCWs to be stack together

Attach corner brackets and threaded -rods to both sides of the wall; install cables & smoke plug

### Retro

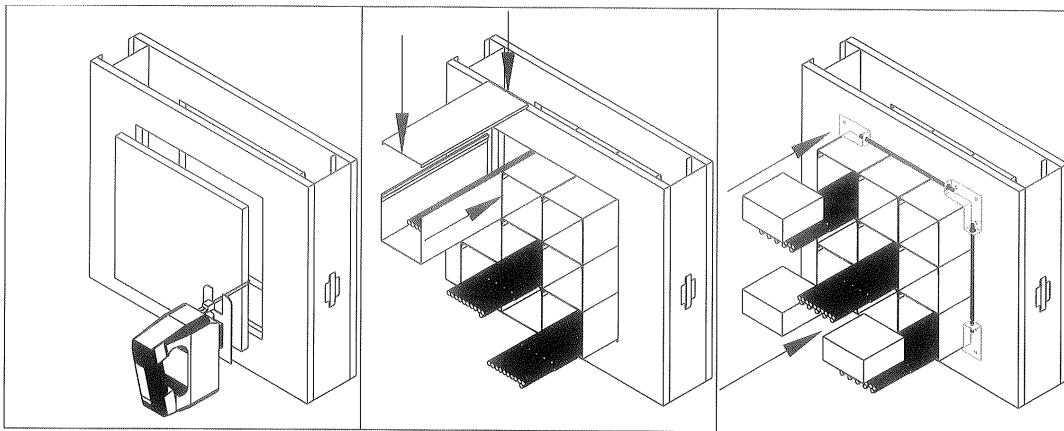

Cut opening to the correct size

Fit cables into the bottom of the FCW-44; close the lid and slide the FCW-44 into the opening; stacking the FCWs together

Attach corner brackets and threaded -rods to both sides of the wall; install cables & smoke plug



Bolt corner brackets together using the thread rod, cut to fit number of FCW44; then install and bolted the corner brackets on both sides of the wall attaching the corner brackets to wall using drywall screws or concrete anchors depending on wall type.

Disclaimer: All technical advices, recommendations and services rendered by the seller are gratis. They are based on technical data which the seller believes to be reliable and are intended for use by person having the skills and know how at their own discretion and risk. In no event will the seller be liable for any consequential damages arising out of the use of this product.

